

Pre-DR Checklist Breadboard or Simulate!

Compiled by Hans Gaensbauer | R1: 8-22-2022

Debugging

- Labeled test points
- Labeled headers
- Multiple ground test points
- Mounting holes
- Box for PCB ID#

RF and High Speed

- Short traces
- No controlled Z stubs/splits
- Ground pours under traces
- Via stitched ground planes
- Length matching
- Modular design

Project

- Fab drawing
- Complete BoM
- US Letter pages
- Complete title block
- Labeled/boxed subcircuits
- Silkscreen name/revision
- Annotated 3dB points/gains

Safety

- Thick traces where necessary
- Compatible logic levels
- Clamps for analog inputs
- RPP or polarized connectors
- Isolated AC/DC sides

Don't Forget:

- ESD diodes
- Fuses/Varistor
- Ferrites
- Freewheeling diodes
- Decoupling caps
- LEDs

Components

Op Amps:

- Supply voltage
- Gain bandwidth product
- Input CM voltage range
- Output voltage range
- Output current

Transistors:

- Correct package
- g_m/H_{fe} @ q point
- Check max VDS/VCE
- Power dissipation

Capacitors:

- Temp
- Failure mode
- ESR
- Voltage rating

Resistors:

- Tolerance
- Temp dependence
- Power dissipation

Regulators:

- I_q
- Droputout voltage
- Efficiency vs I_{out} (max)

uCs:

- In stock?
- Peripherals
- Supply voltage

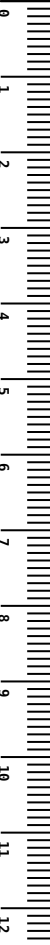
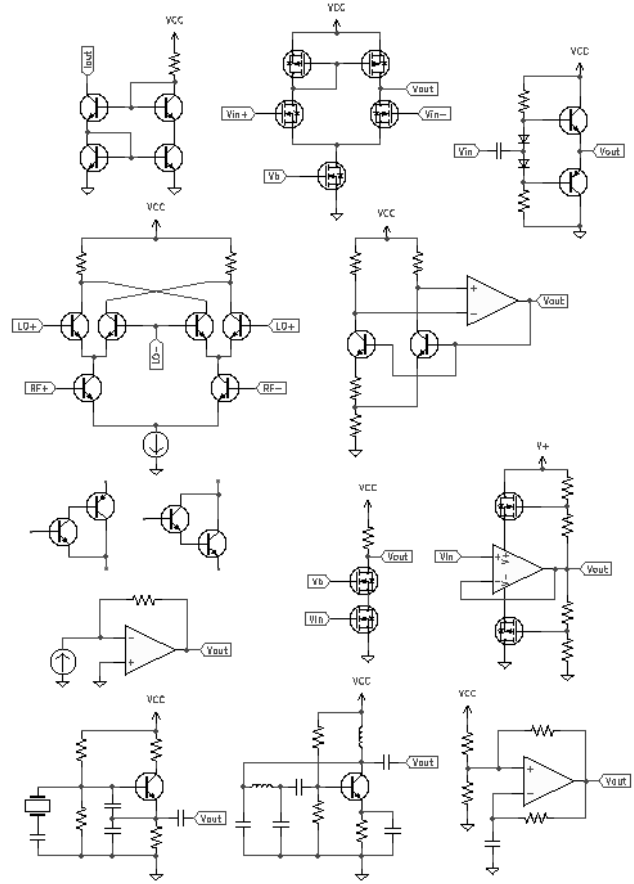

Pre-DR Checklist Breadboard or Simulate!

Compiled by Hans Gaensbauer | R1: 8-22-2022

Debugging

- Labeled test points
- Labeled headers
- Multiple ground test points
- Mounting holes
- Box for PCB ID#

RF and High Speed

- Short traces
- No controlled Z stubs/splits
- Ground pours under traces
- Via stitched ground planes
- Length matching
- Modular design

Project

- Fab drawing
- Complete BoM
- US Letter pages
- Complete title block
- Labeled/boxed subcircuits
- Silkscreen name/revision
- Annotated 3dB points/gains

Safety

- Thick traces where necessary
- Compatible logic levels
- Clamps for analog inputs
- RPP or polarized connectors
- Isolated AC/DC sides

Don't Forget:

- ESD diodes
- Fuses/Varistor
- Ferrites
- Freewheeling diodes
- Decoupling caps
- LEDs

Components

Op Amps:

- Supply voltage
- Gain bandwidth product
- Input CM voltage range
- Output voltage range
- Output current

Transistors:

- Correct package
- g_m/H_{fe} @ q point
- Check max VDS/VCE
- Power dissipation

Capacitors:

- Temp
- Failure mode
- ESR
- Voltage rating

Resistors:

- Tolerance
- Temp dependence
- Power dissipation

Regulators:

- I_q
- Droputout voltage
- Efficiency vs I_{out} (max)

uCs:

- In stock?
- Peripherals
- Supply voltage

